

G074 Volume of prisms

Q1.

Here is a cuboid.

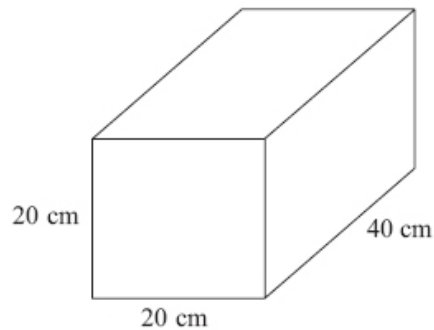

Diagram **NOT**
accurately drawn

Work out the volume of the cuboid.

(Total for Question is 3 marks)

Q2.

Here is a triangular prism.

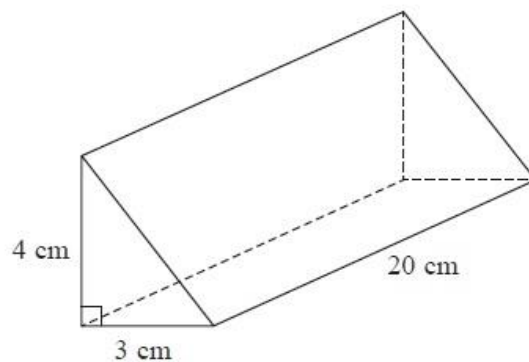

Diagram **NOT**
accurately drawn

Work out the volume of this triangular prism.

(Total for Question is 4 marks)

Q3.

The diagram shows a prism.

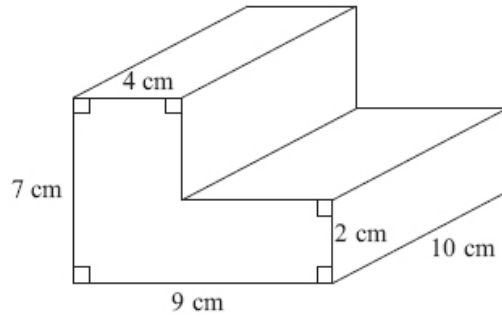

Diagram **NOT** accurately drawn

Work out the volume of the prism.

.....cm³

(Total for Question is 4 marks)

Q4.

Here is a solid prism.

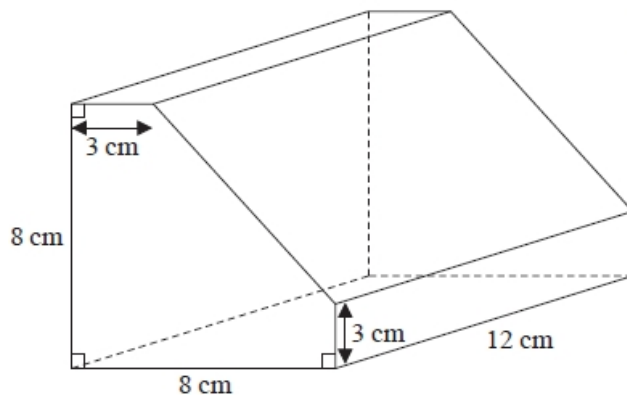

Diagram **NOT**
accurately drawn

Work out the volume of the prism.
You must show all your working.

..... cm³

(Total for question = 4 marks)

Q5.

A container is in the shape of a cuboid.

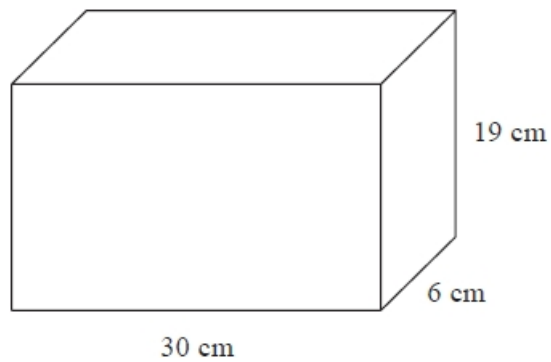

The container is $\frac{2}{3}$ full of water.

A cup holds 275 ml of water.

What is the greatest number of cups that can be completely filled with water from the container?

.....
(Total for question = 4 marks)

Q6.

The diagram shows a sand pit.
The sand pit is in the shape of a cuboid.

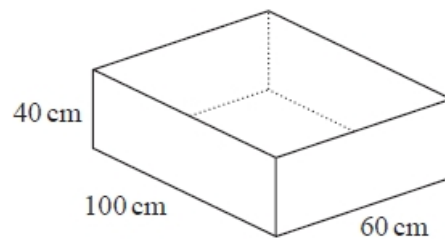

Sally wants to fill the sand pit with sand.
A bag of sand costs £2.50
There are 8 litres of sand in each bag.

Sally

"The sand will cost less than £70"

Show that Sally is wrong.

(Total for question is 5 marks)

Q7.

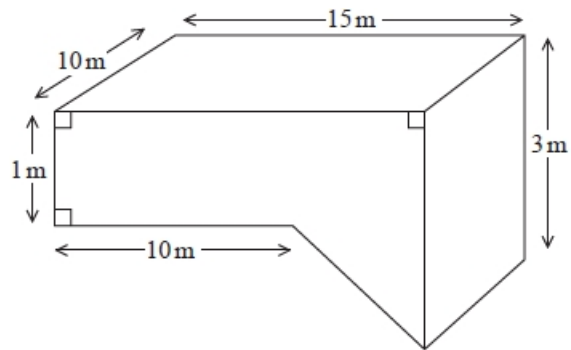

The diagram shows a swimming pool.

The swimming pool is in the shape of a prism.

The swimming pool is filled with water at a rate of 5 litres per second.

Jeremy has 10 hours to fill the swimming pool.

$1 \text{ m}^3 = 1000 \text{ litres}$.

Will he completely fill the swimming pool in 10 hours?

You must show all your working.

(Total for question = 5 marks)

Q8.

The diagram shows an oil tank in the shape of a prism.
The cross section of the prism is a trapezium.

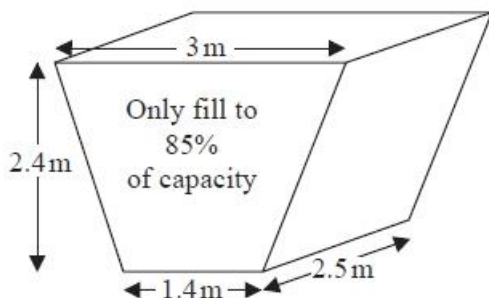

The tank is empty.

Oil flows into the tank.

After one minute there are 300 litres of oil in the tank.

Assume that oil continues to flow into the tank at this rate.

- (a) Work out how many **more** minutes it takes for the tank to be 85% full of oil.
(1 m³ = 1000 litres)

..... minutes
(5)

The assumption about the rate of flow of the oil could be wrong.

- (b) Explain how this could affect your answer to part (a).

.....
.....

(1)

(Total for question = 6 marks)

Q9.

A water trough is in the shape of a prism.

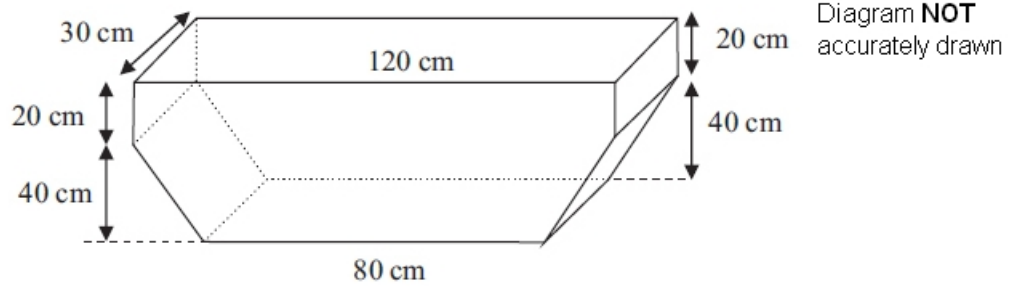

Hamish fills the trough completely.

Water leaks from the bottom of the trough at a constant rate.

2 hours later, the level of the water has fallen by 20 cm.

Water continues to leak from the trough at the same rate.

How many more minutes will it take for the trough to empty completely?

..... minutes

(Total for Question is 6 marks)

Q10.

The diagram shows a tank in the shape of a cuboid.
It also shows a container in the shape of a cuboid.

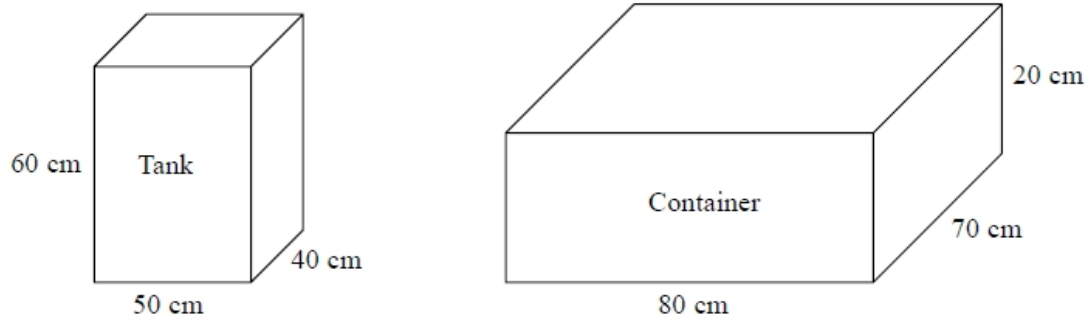

The tank is full of oil.
The container is empty.
35% of the oil from the tank is spilled.
The rest of the oil from the tank is put into the container.
Work out the height of the oil in the container.
Give your answer to an appropriate degree of accuracy.

..... cm

(Total for question = 5 marks)

Q11.

Jane has a carton of orange juice.
The carton is in the shape of a cuboid.

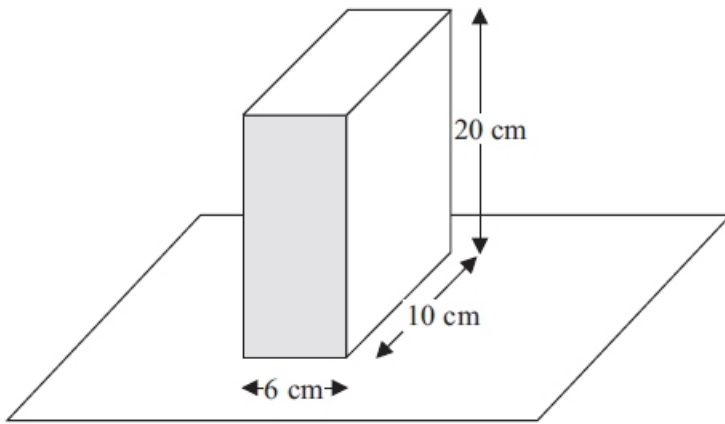

Diagram **NOT** accurately drawn

The depth of the orange juice in the carton is 8 cm.

Jane closes the carton.

Then she turns the carton over so that it stands on the shaded face.

Work out the depth, in cm, of the orange juice now.

..... cm

(Total for Question is 3 marks)

Q12.

The diagram shows a fish tank in the shape of a cuboid.

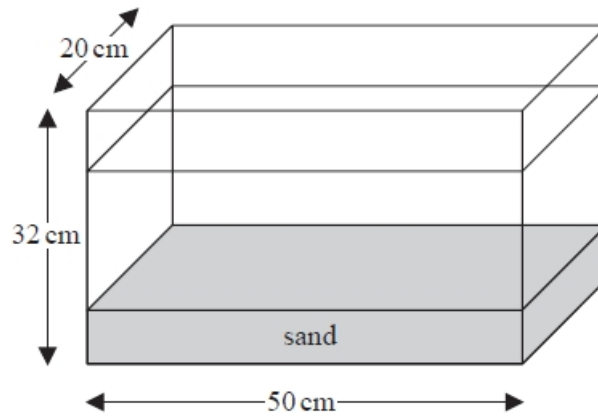

The dimensions of the tank are 50 cm by 32 cm by 20 cm.

The tank is $\frac{3}{4}$ full of water and sand.

The ratio of the volume of water to the volume of sand is 5 : 1

Work out the number of litres of water in the tank.

You must show all your working.

..... litres

(Total for question = 5 marks)

Q13.

Sanders has a water tank for storing rainwater.

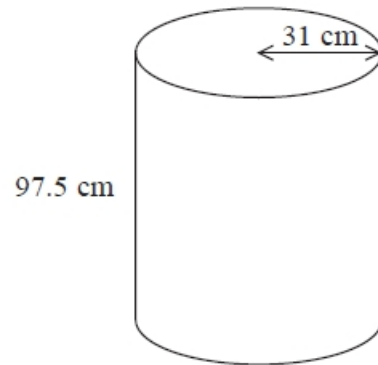

Diagram **NOT** accurately drawn

The tank is in the shape of a cylinder.
The radius of the cylinder is 31 cm.
The height of the cylinder is 97.5 cm.

The tank is full of water.

Work out an estimate for the volume of water in the tank.
Give your answer in litres.
You must show your working.
Use $1000 \text{ cm}^3 = 1 \text{ litre}$.

..... litres

(Total for question = 3 marks)

Q14.

The diagram shows a container used to store oil.

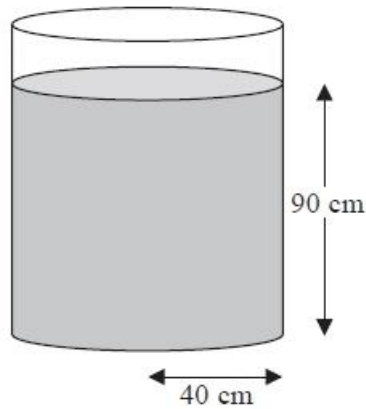

Diagram **NOT**
accurately drawn

The container is in the shape of a cylinder of radius 40 cm.

The height of the oil in the container is 90 cm.

65 litres of oil are taken from the container.

1 litre = 1000 cm³.

Work out the new height of the oil in the container.

Give your answer correct to one decimal place.

.....cm

(Total for Question is 4 marks)